



TRASH RACK

Keep your irrigation channels clear and ensure your pumps run at peak efficiency with Collier & Miller's game-changing Trash Rack.

Designed to ensure the smooth flow of irrigation water, the C&M Trash Rack effectively filters debris, including flyaway grass, roly poly, cotton trash and wheat stubble, preventing troublesome pump station blockages.

This robust system features a front grate and a rotating rack that lifts out of the water when not in use.



FEATURES & BENEFITS

- Filters debris, including flyaway grass, roly poly, cotton trash and wheat stubble
- Heavy-duty grate and rotating rack system
- Discharge conveyor
- Hydraulic power pack
- Robust engineering and heavy-duty design
- Custom design and additions available



COLLIER & MILLER



**SCAN FOR
MORE INFO**

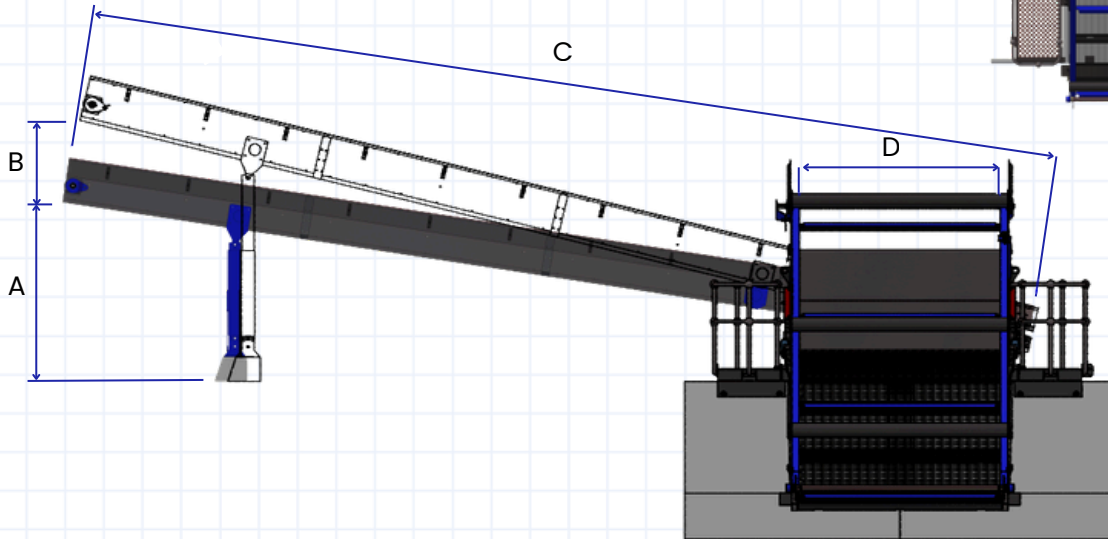
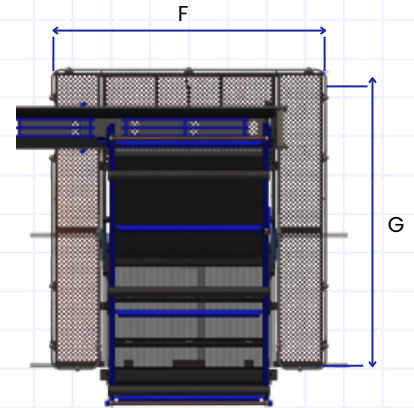
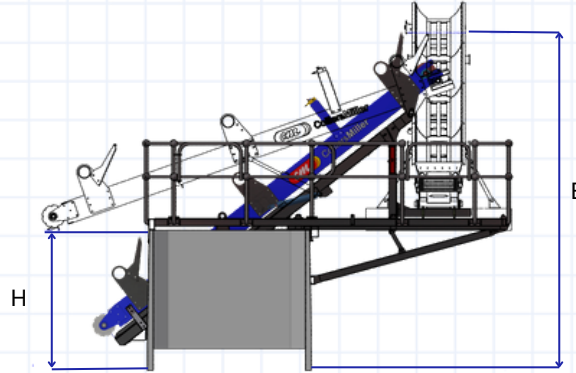
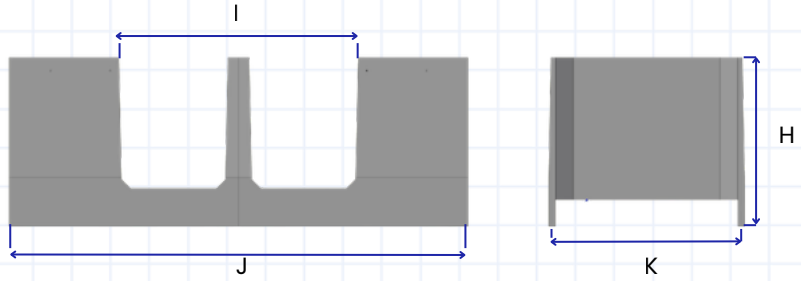

MODEL	CMTRE
DESCRIPTION	C&M Trash Rack Elevator
A = Conveyor Height (Minimum)	2188mm
B = Conveyor Height Adjustment	1016mm
C = Conveyor Length	12000mm
D = Elevator Width	2470mm
E = Elevator Height	4648mm
F = Platform Width	4480mm
G = Platform Length	4922mm
H = Weir Height	1930mm
I = Weir Opening	2760mm
J = Weir Width	5300mm
K = Weir Length	2255mm